



150 LB. CAST CARBON STEEL FLANGED & BUTTWELDED "Y" STRAINERS

MODELS: C8-150 & C7-150

PRESSURE-TEMPERATURE RATINGS	
STEAM:	150 psi @ 565 ° F
WOG:	285 psi @ 100 ° F

SERVICE RECOMMENDATIONS

These strainers are designed for dependable service under demanding conditions. They offer protection to mechanical equipment such as pumps and valves at high temperatures and pressures. Self cleaning is easily accomplished by installing a valve to the NPT connection. These strainers are commonly used in the oil and petrochemical industries.

FEATURES

All sizes feature a bolted cover machined to receive the screen. Cover gaskets are stainless steel spiral wound. Bolting is ASTM A193-B7/ASTM A194-2H. Covers are normally furnished with a blowoff tap, but, without a plug.

Heavy gauge 304 stainless steel screens are normally furnished in the following perforations:

SERVICE:	1/2" - 4"	5" to 14"
Steam:	.033"	.045"
Liquid :	.062"	1/8"

Other materials, such as Monel, Hastelloy C, & Alloy-20 are available. Other perforation sizes and/or mesh lining is also available.

CONSTRUCTION

As a standard, the body is constructed of Carbon Steel ASTM A216 Gr. WCB. Both models are available in Chrome Moly (ASTM A217 Gr. WC6 & WC9). The standard cover is HRS plate. The bodies of both the C8-150 & C7-150 are designed to 150 lb. ANSI specifications. Model C8-150 has RF flanges and model C7-150 ends are machined to match standard weight pipe. All models have machined seats in the body & cover to ensure accurate screen alignment.

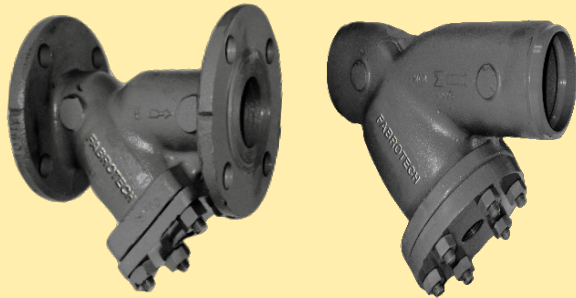

Model C8-150

Model C7-150

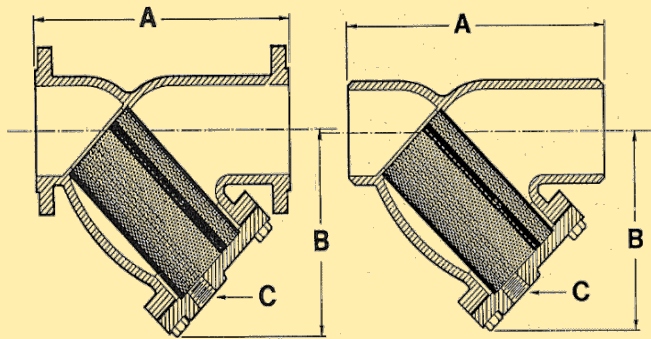

DIMENSIONS & WEIGHTS APPROXIMATE
(Apply for certified drawings)

SIZE	in. mm	1/2" 15	3/4" 20	1" 25	1 1/4" 32	1 1/2" 40	2" 50	2 1/2" 65	3" 80	4" 100	5" 125	6" 150	8" 200	10" 250	12" 300	14" 350
A	C8-150	6 1/2	7 3/8	7 3/8	7	7 1/8	7 7/8	9 3/4	10 1/16	12 1/8	15 5/8	18 1/2	21 3/8	26	29 7/8	33 1/4
	C7-150	6 5/8	8 5/16	7 7/8	10 1/8	10 1/4	8 5/8	10 5/8	12	14 1/2	16 3/8	19 5/16	23 3/8	27 3/8	32	35
B	C8-150	3 1/2	3 3/4	3 3/4	4 3/4	4 3/4	5 1/4	6 1/2	7	8 1/4	11 1/4	13 1/2	15 1/2	18 1/2	22 1/4	25
	C7-150	3 1/2	3 3/4	5 1/2	5 1/2	5 1/2	5 1/4	6 1/2	7	8 1/4	11 1/4	13 1/2	15 3/4	19	22 1/4	25
C	NPT	3/8	1/2	1/2	1/2	1/2	1/2	1	1	1	1 1/2	2	2	2	2	2
WT (lb)	C8-150	5 1/2	10 1/4	10 1/4	9 3/4	12 1/2	21	32	35	55	90	140	220	360	645	980
	C7-150	3	9	9	12	13	10	14	20	40	60	90	168	250	440	765
Cv		18	18	18	22	42	70	110	160	260	400	570	950	1600	2200	2400

FABROTECH INDUSTRIES, INC.
2089 NINTH AVENUE, RONKONKOMA, NEW YORK 11779
TEL: (631) 467-2040 FAX: (631) 467-2196 e-mail: info@fabrotech.com
www.fabrotech.com