



300 LB. CAST CARBON STEEL FLANGED & BUTTWELD "Y" STRAINERS

MODELS: C8-300 & C7-300

PRESSURE-TEMPERATURE RATINGS	
STEAM:	300 psi @ 838° F
WOG:	740 psi @ 100° F

SERVICE RECOMMENDATIONS

Fabrotech C8-300 and C7-300 are designed for dependable service under demanding conditions. They offer protection to mechanical equipment such as pumps and valves at high temperatures and pressures. Self cleaning is easily accomplished by installing a valve to the NPT connection. These strainers are commonly used in the oil and petrochemical industries.

FEATURES

All sizes feature a bolted cover machined to receive the screen. Cover gaskets are stainless steel spiral wound. Studs are carbon steel. Covers are normally furnished with a blowoff tap, but, without a plug.

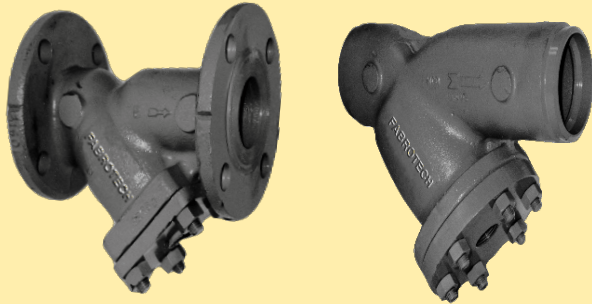

Model C8-300

Model C7-300

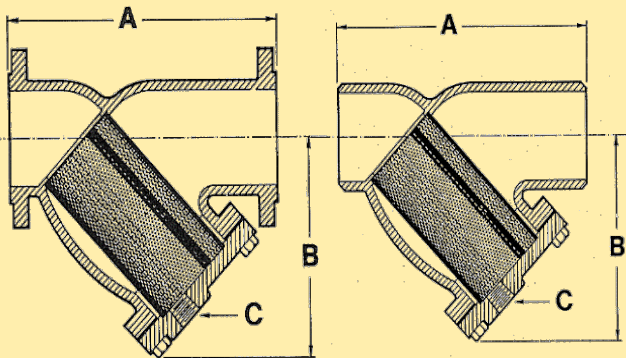

Heavy gauge 304 stainless steel screens are normally furnished in the following perforations:

SERVICE:	1/2" - 4"	5" to 14"
Steam:	.033"	.045"
Liquid :	.062"	1/8"

Monel, Hastelloy C, & Alloy-20 screens are available. Other perforation sizes and/or mesh lining is also available

CONSTRUCTION

As a standard, the body is constructed of Carbon Steel ASTM A216 Gr. WCB. Both models are available in Chrome Moly (ASTM A217 Gr. WC6 & WC9). The standard cover is HRS plate. The bodies of both the C8-300 & C7-300 are designed to 300 lb. ANSI specifications. Model C8-300 has RF flanges and model C7-300 ends are machined to match standard weight pipe. All models have machined seats in the body & cover to ensure accurate screen alignment.

DIMENSIONS & WEIGHTS APPROXIMATE
(Apply for certified drawings)

SIZE	in.	1/2"	3/4"	1"	1 1/4"	1 1/2"	2"	2 1/2"	3"	4"	5"	6"	8"	10"	12"	14"
	mm	15	20	25	32	40	50	65	80	100	125	150	200	250	300	350
A	C8-300	6 5/8	8 1/3	8 5/16	10 1/8	10 1/4	9 5/8	10 5/8	12	14 1/2	19 1/3	19 5/16	23 3/8	27 3/8	32	38
	C7-300	6 5/8	8 5/16	7 7/8	10 1/8	10 1/4	8 5/8	10 5/8	12	14 1/2	16 3/8	19 5/16	23 3/8	27 3/8	32	35
B	C8-300	3 1/2	3 3/4	3 3/4	5 1/2	5 1/2	5 1/4	6 1/2	7	8 1/4	11 1/4	13 1/2	15 3/4	19	21 3/4	25
	C7-300	3 1/2	3 3/4	5 1/2	5 1/2	5 1/2	5 1/4	6 1/2	7	8 1/4	11 1/4	13 1/2	15 3/4	19	22 1/4	25
C	NPT	3/8	1/2	1/2	1/2	1/2	1/2	1	1	1 1/2	2	2	2	2	2	2
WT (lb)	C8-300	7 1/2	12 1/2	14	26	26	26	40	53	94	162	185	260	410	635	1450
	C7-300	3	9	9	12	13	10	14	20	40	60	90	168	250	440	765
Cv		18	18	18	22	42	70	110	160	260	400	570	950	1600	2200	2400

FABROTECH INDUSTRIES, INC.

2089 NINTH AVENUE, RONKONKOMA, NEW YORK 11779

TEL: (631) 467-2040 FAX: (631) 467-2196 e-mail: info@fabrotech.com

www.fabrotech.com