



# 600 LB. CAST CARBON STEEL FLANGED & BUTTWELD "Y" STRAINERS

## MODELS: C8-600 & C7-600

PRESSURE-TEMPERATURE RATINGS	
STEAM	1480 psi @ 100 Deg F
WOG	1480 psi @ 100 Deg F

### SERVICE RECOMMENDATIONS

These strainers are designed for dependable service under demanding conditions created by high temperatures and pressures. Installation of a strainer before any automatic equipment will ensure trouble free service and avoid costly repairs caused by the existence of foreign matter in pipelines.

### FEATURES

All sizes have Cast Carbon Steel (ASTM A216 Gr. WCB) bodies with bolted covers machined to receive the screen. The stainless steel spiral wound cover gaskets are designed for high temperature service. Studs are A193-B7. Nuts are A194-2H heavy hex. Covers are normally furnished with a blowoff tapping, but without a plug. Ring Type Joint ends (RTJ) are available.

### SCREENS

Heavy gauge 304 stainless steel screens are normally furnished in the following perforations:

SERVICE:	1/2" - 4"	5" to 14"
Steam:	.033"	.045"
Liquid :	.062"	1/8"

Other materials, like Monel, Hastelloy C, & Alloy-20 are available. Other perforation sizes and/or mesh lining is also available.

### CONSTRUCTION

Extremely rugged & durable bodies constructed from Carbon Steel (ASTM A216 Gr. WCB). Both models are available in Chrome Moly (ASTM A217 Gr. WC6 & WC9). The standard cover is HRS plate. The bodies of both the C8-600 & C7-600 are designed to meet 600 lb. ANSI specifications. Model C8-600 has RF flanges and model C7-600 ends are machined to match schedule 80 pipe. All models have machined seats in the body & cover to ensure accurate screen alignment.

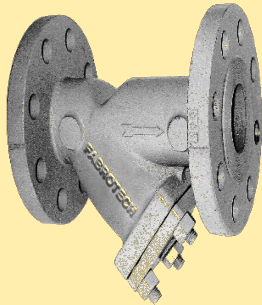

Model C8-600



Model C7-600

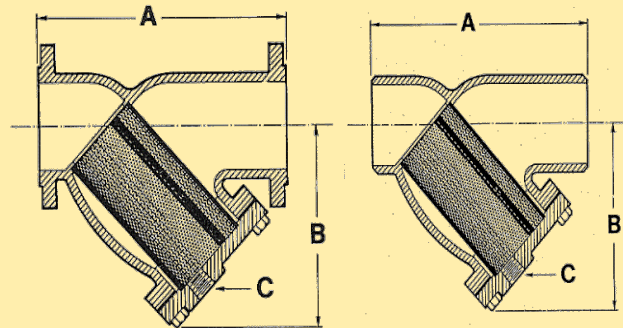

DIMENSIONS & WEIGHTS APPROXIMATE  
(Apply for certified drawings)

SIZE	in.	1/2"	3/4"	1"	1 1/4"	1 1/2"	2"	2 1/2"	3"	4"	5"	6"	8"	10"	12"
	mm	15	20	25	32	40	50	65	80	100	125	150	200	250	300
A	C8-600	6 5/8	8 5/16	8 5/16	10 1/8	10 1/4	11	12	13 1/2	17 15/16	22 1/4	25 5/8	31 3/4	37 11/16	41
	C7-600	6 5/8	8 5/16	8 5/16	10 1/8	10 1/4	11	12	13 1/2	18	22 1/4	25 5/8	31 3/4	37 11/16	45 1/2
B	C8-600	3 1/2	3 3/4	3 3/4	5 1/2	5 1/2	7	8 1/4	9 1/4	12 1/2	15	20	24	28 1/2	29 5/16
	C7-600	3 1/2	3 3/4	3 3/4	5 1/2	5 1/2	7	8 1/4	9 1/4	12 1/2	15	20	24	28 1/2	34 1/2
C	NPT	3/8	1/2	1/2	1/2	1/2	1/2	1	1	1 1/2	2	2	2	2	2
WT (lb)	C8-600	8	10 1/2	14	26	28	40	55	70	135	254	325	550	1090	1558
	C7-600	3	9	9	12	15	30	32	38	77	134	220	390	706	880
Cv		18	18	18	22	42	70	110	160	260	400	570	950	1600	2200

Also available in sizes 14" thru 24"

## FABROTECH INDUSTRIES, INC.

2089 NINTH AVENUE, RONKONKOMA, NEW YORK 11779

TEL: (631) 467-2040 FAX: (631) 467-2196 e-mail: info@fabrotech.com

[www.fabrotech.com](http://www.fabrotech.com)